

## FT68 Deodorising Unit



### FEATURES

- *Stainless steel pressure vessel*
- *Comprehensive control panel and instructions*
- *Liquid ring vacuum pump*
- *Steam ejector*
- *Condenser*
- *Electrical heating of the oil*
- *Internal cooling coil*
- *Extraction pump*
- *Polishing filter*
- *Vacuum to 1 Torr*
- *Temperatures to 250°C*
- *Internal steam sparge*

### BENEFITS

- *Only 25 litres of oil to be processed*
- *Safe and easy to use*
- *Economical*

The Armfield Deodorising Unit is a floor-standing batch processing vessel suitable for steam stripping of fatty acids from edible oils.

## Description

The deodorising process vessel has a batch size of 25 litres and is mounted in a floor-standing stainless steel framework which also houses the high vacuum equipment, control console, discharge pump and polishing filter.

A 3.0kW electrical heating element is incorporated in the vessel to heat the oil to temperatures of up to 250°C. The vessel also contains a special steam distribution tube which allows the thorough steam/oil mixing required.

Operating temperature is selected on an electronic temperature controller and is recorded on a continuous chart recorder both of which are housed in the control console.

An immersed cooling water coil provides a means of reducing the oil temperature on completion of the process.

A multi-stage vacuum system incorporates a steam ejector, condenser and liquid ring vacuum pump to achieve vacuum levels less than 5mm Hg (ABS), 6.5 mbar in the process vessel. Accurate indication of the vessel pressure is achieved using an electronic pressure transmitter which indicates the vacuum level down to 1 Torr on a digital display in the control panel.

Fatty acids and other compounds carried over with the steam are condensed in a spray type condenser and they pass to drain with the sealing water of the liquid ring vacuum pump.

On completion of the deodorising process, the oil is pumped out of the vessel through a 'polishing' filter which removes any remaining particles in the finished oil.

The deodoriser vessel is designed in accordance with the BS 5500 code for pressure vessels.

All materials in contact with process fluid are of stainless steel.

## Modes of Operation

Removal of free fatty acid, ketone and acetaldehyde traces in edible oils is an important stage in the refining procedure as it is these compounds which impart an unpleasant odour to the oils. The method used for this removal is vacuum steam distillation under very high temperature and vacuum conditions. The Armfield Deodoriser achieves this using a unique steam mixing/contactor and multi-stage vacuum system.

### Deodorising:

The oil is heated under vacuum using direct steam to provide the agitation for good heat transfer. When the desired temperature and pressure are achieved, the direct steam injection is adjusted to impart a high degree of turbulence to the oil which ensures good physical contact of the steam with the oil. The impurities are carried over in the vapour and condensed in the vacuum condenser, the resulting condensate blending with the liquid ring vacuum pump sealant to be discharged to drain.

### Polishing:

After deodorisation, the oil refining process is complete and the oil can be consumed or used in the manufacture of other products. It must therefore be free of any trace of contaminants and, to achieve this, it is pumped through a fine 'polishing' filter which removes particles down to 6.0 micron giving a bright oil as product.

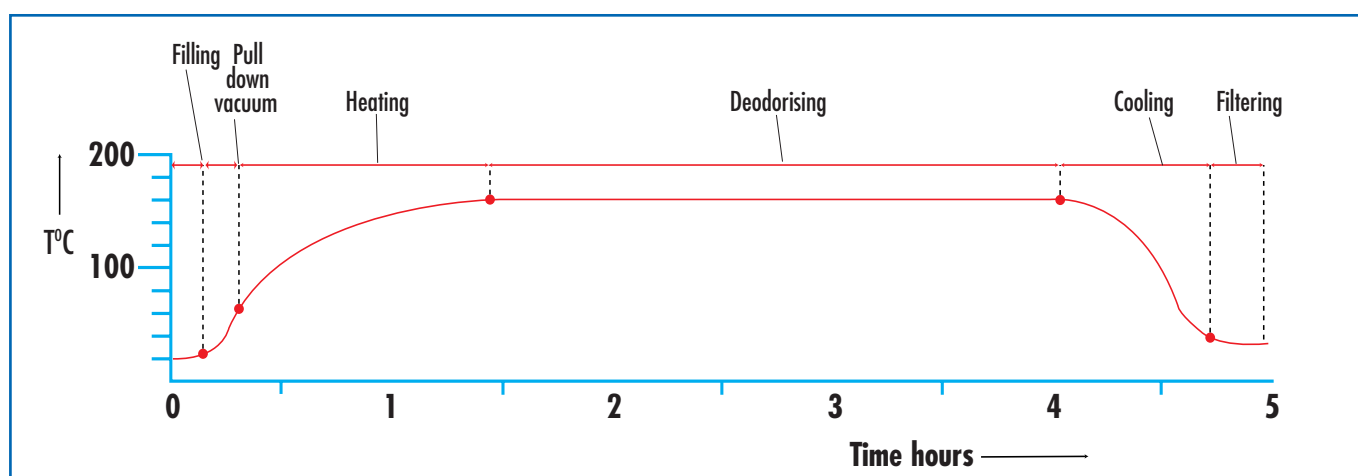

Typical printout of process temperature recorder

### Performance

Independent deodorisation tests carried out by: Manchester Metropolitan University, Department of Food and Consumer Technology, using refined and bleached rapeseed oil gave the following analytical results:-

	Refined bleached oil	Deodorised oil
Free fatty acid	0.1%	0.04%
Soap in oil	nil	nil
Colour	20 Yellow 0.5 Red	10 Yellow 0.4 Red

### Capabilities

- operation of small scale version of the industrial process
- determination of optimum process conditions for different oil types
- effect of variation of process temperature
- effect of variation of process pressure
- effect of variation of quantity of direct steam added
- effect of variation of overall process time.

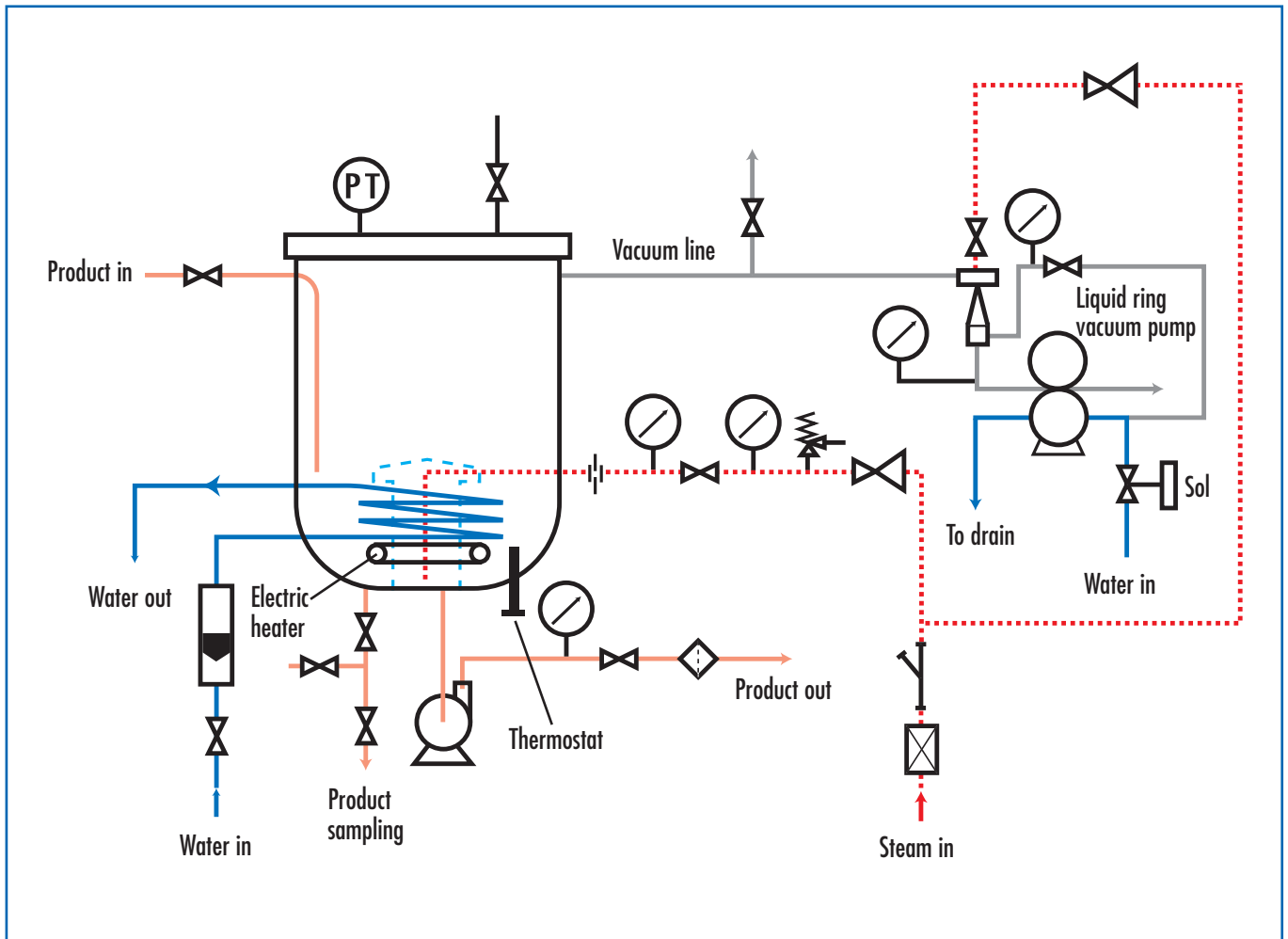

FT68 Schematic diagram



**Head Office:**

**Armfield Limited**  
Bridge House  
West Street  
Ringwood  
Hampshire  
BH24 1DY  
England

**Tel:**  
+44 (0)1425 478781

**Fax:**  
+44 (0)1425 470916

**E mail:**  
sales@armfield.co.uk

**URL:**  
<http://www.armfield.co.uk>

**USA Office:**

**Armfield Inc.**  
436 W. Commodore Blvd (#2)  
Jackson, NJ 08527

**Tel:**  
(732) 928-3332

**Fax:**  
(732) 928-3542

**E mail:**  
armfield@optonline.net



## Unit specifications

### Deodoriser vessel:

Overall volume: 60.0 litres  
Working volume: 25.0 litres  
Product temperature maximum: 250°C  
Working pressure: less than 5.0mm Hg (ABS), 6.5mbar  
Heating element: 3.0kW  
Cooling coil area: 0.1m<sup>2</sup>  
Direct steam flow rate: 0.0-1.0 kg/hr

### Vacuum system:

Ejector steam: 7 bar, 4kg/hr

### Vacuum pump:

Type: liquid ring  
Number of stages: two  
Motor power: 2.0kW  
Sealant: water  
Sealant flow rate: 10.0lpm

### Polishing filter:

Type: replaceable cartridge  
Filter element size: 6.0 micron

## Electrical Supply

FT68-C: 415V/3ph/50Hz, (11kW)  
FT68-D: 208V/3ph/60Hz, (7kW)  
FT68-E: 380V/3ph/50Hz, (11kW)  
FT68-F: 220V/3ph/60Hz, (7kW)

## Cooling water supply

20.0 lpm @ 3.0 bar min/5.0 bar max pressure @15°C

## Steam supply

4.0 bar minimum; 10kg/hr

## Overall dimensions

Height: 1.58m  
Width: 1.28m  
Depth: 0.68m

## Shipping specification

Volume: 2.5m<sup>3</sup>  
Gross weight: 500kg